



LED High Bay High Quality LED

- ⦿ High Performance , Durable
- ⦿ Excellent Heat Sink
- ⦿ Energy Saving more than 50%
- ⦿ Long Life Time

WWW.LEDSAVE.CO.TH

APPLICATIONS : Warehouse , Plant , Suppermarket , Storage room , Workshop , Stadium and Other



SPECIFICATION

Product Model	HB03-150N
Power	150W
Lumen	24,000 Lumen
Lumen/Watt	160 Lumen/Watt
Input Voltage	AC100-240V , 50-60 Hz
Surge Protection	Surge immunity Line-Earth 4KV, Line-Line 2KV , Compliance to EN61000-4-2,3,4,5,6,8,11 ; EN61547
Power Factor	PF > 0.95 +/- 2%
Operation Temperature	- 40°C to 70°C
Color Temperature (CCT)	2,700 / 5,000 / 6,500 K
Color Rendering (Ra)	CRI > 80
Material	Aluminium + CU
Beam Angle	60° / 110°
IP Rate	IP 65
THDi (%)	< 10%
Life Time	50,000 Hrs.
Dimension (AxB)	Ø460x390 mm.
Weight	4.3 Kg.

PHOTOMETRIC DATA

DIMENSION

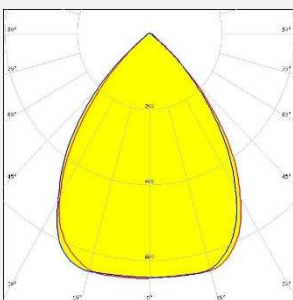

Beam Angle 60°

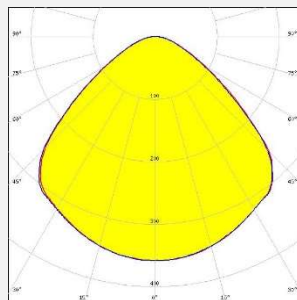

Beam Angle 110°

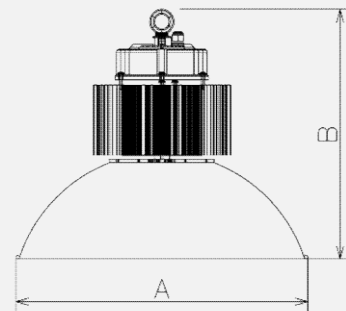

LEDSAVE (THAILAND) CO.,LTD.

15/16 Moo 18 T.Bangphli-Yai A.Bangphli Samutprakan 10540 โทร. 02-045-4768-9 , แฟกซ์ 02-045-3884-5

Email : admin@ledsave.co.th , Line : @LEDSAVE , Facebook.com/Ledsave

