



LED High Bay High Quality LED

- ⦿ High Performance , Durable
- ⦿ Excellent Heat Sink
- ⦿ Energy Saving more than 50%
- ⦿ Long Life Time

WWW.LEDSAVE.CO.TH

APPLICATIONS : Warehouse , Plant , Suppermarket , Storage room , Workshop , Stadium and Other



SPECIFICATION

| Product Model | HB03-250N |
|-------------------------|-------------------------------------------------------------------------------------------------|
| Power | 250W |
| Lumen | 38,000 Lumen |
| Lumen/Watt | 152 Lumen/Watt |
| Input Voltage | AC100-240V , 50-60 Hz |
| Surge Protection | Surge immunity Line-Earth 4KV, Line-Line 2KV , Compliance to EN61000-4-2,3,4,5,6,8,11 ; EN61547 |
| Power Factor | PF > 0.95 +/- 2% |
| Operation Temperature | - 40°C to 70°C |
| Color Temperature (CCT) | 2,700 / 5,000 / 6,500 K |
| Color Rendering (Ra) | CRI > 80 |
| Material | Aluminium + CU |
| Beam Angle | 60° / 110° |
| IP Rate | IP 65 |
| THDi (%) | < 10% |
| Life Time | 50,000 Hrs. |
| Dimension (AxB) | Ø460x460 mm. |
| Weight | 5.9 Kg. |

PHOTOMETRIC DATA

DIMENSION

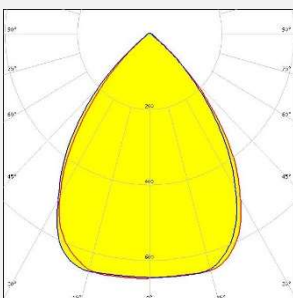

Beam Angle 60°

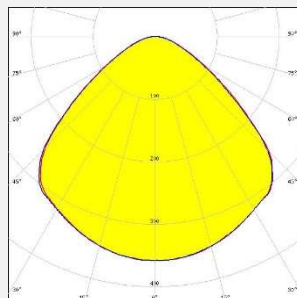

Beam Angle 110°

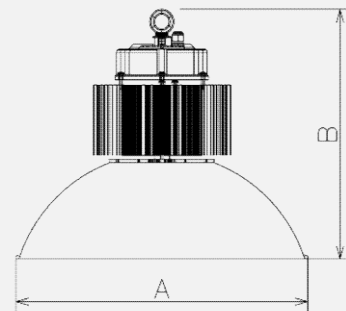

LEDSAVE (THAILAND) CO.,LTD.

15/16 Moo 18 T.Bangphli-Yai A.Bangphli Samutprakan 10540 โทร. 02-045-4768-9 , แฟกซ์ 02-045-3884-5

Email : admin@ledsave.co.th , Line : @LEDSAVE , Facebook.com/Ledsave

